

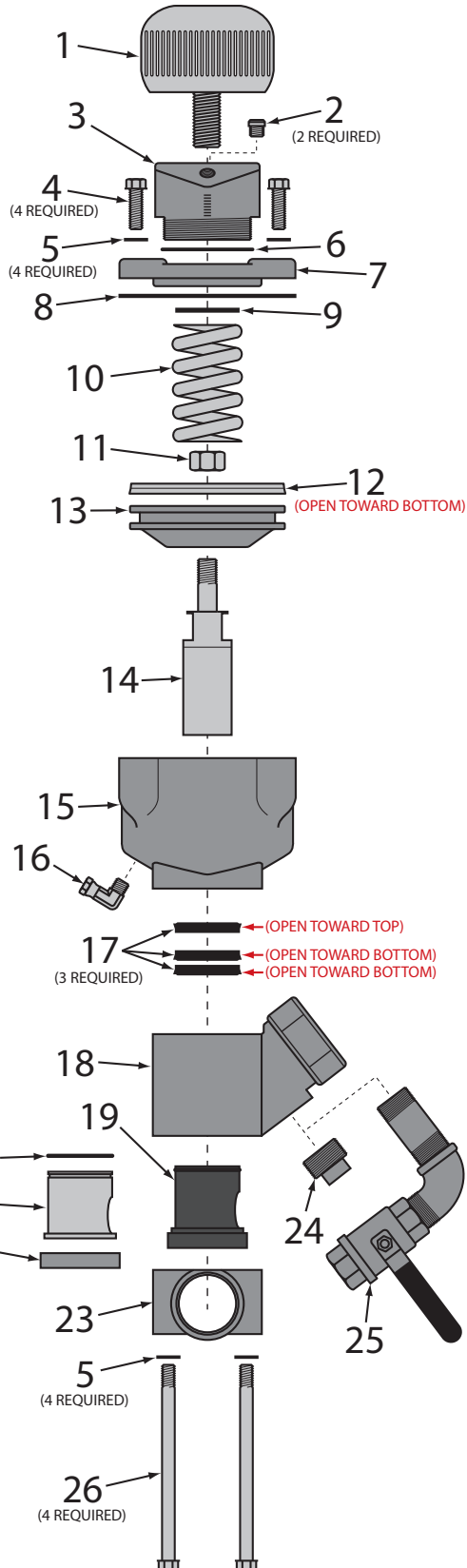

ASSEMBLY INSTRUCTIONS



T2V Plunger Valve

	888-2152-00099PB	T2V, REPAIR KIT W/TC SLEEVE, INCLUDES #6, 8, 12, 14, (3)17, 20, 21 & 22 (PIRATE BRAND)
	888-2152-00098PB	T2V, SEALS ONLY W/ URETHANE SEAT, INCLUDES #6, 8, 12, (3)17, 20 & 22 (PIRATE BRAND)
	888-2152-10099PB	T2V, REPAIR KIT W/ URETHANE SLEEVE, INCLUDES #6, 8, 12, 14, (3)17, & 19 (PIRATE BRAND)
	888-2152-10098PB	T2V, SEALS ONLY W/ URETHANE SLEEVE, INCLUDES #6, 8, 12, (3)17, & 19 (PIRATE BRAND)
2	888-2014-300PB	VENT 1/8" (2 REQUIRED)
4	888-7010-50707PB	HEX BOLT, 3/8" UNC x 1-1/4" (4 REQUIRED)
5	888-7027-50302PB	APV, APV II & T2V, FLAT WASHER 3/8" SAE (4 REQUIRED)
11	888-2149-00008PB	APV & T2V NUT (PIRATE BRAND)
12	888-2148-00004PB	APV, APV II & T2V, PISTON SEAL (GREEN URETHANE) (PIRATE BRAND)
14	888-2152-00007PB	T2V, PLUNGER, TUNGSTEN CARBIDE
16	888-4203-50000PB	SWIVEL 90°, 1/8" MNPT X 1/8" F
17	888-2152-00006PB	T2V, PLUNGER SEAL W/O-RING (3 REQUIRED) (PIRATE BRAND)
19	888-2152-10013PB	T2V, SLEEVE, URETHANE (PIRATE BRAND)
20	888-2152-00021PB	T2V, O-RING FOR TC SLEEVE (PIRATE BRAND)
21	888-2152-00013PB	T2V, SLEEVE, TUNGSTEN CARBIDE (PIRATE BRAND)
22	888-2152-00010PB	T2V, SEAT, URETHANE (PIRATE BRAND)
23	888-2152-00015PB	T2V, BASE, 1-1/4" NPT (PIRATE BRAND)
	888-2152-00011PB	T2V, BASE, 1-1/2" NPT (PIRATE BRAND)
24	888-3014-106PB	PIPE PLUG, GALV, 1"
25	999-8403-00054PB	APV II & T2V CLEANOUT BALL VALVE ASSY (PIRATE BRAND)
26	888-7010-50795PB	HEX BOLT, 3/8" UNC x 4-3/4" (4 REQUIRED)

